

TOP ORIENTATION VIEW

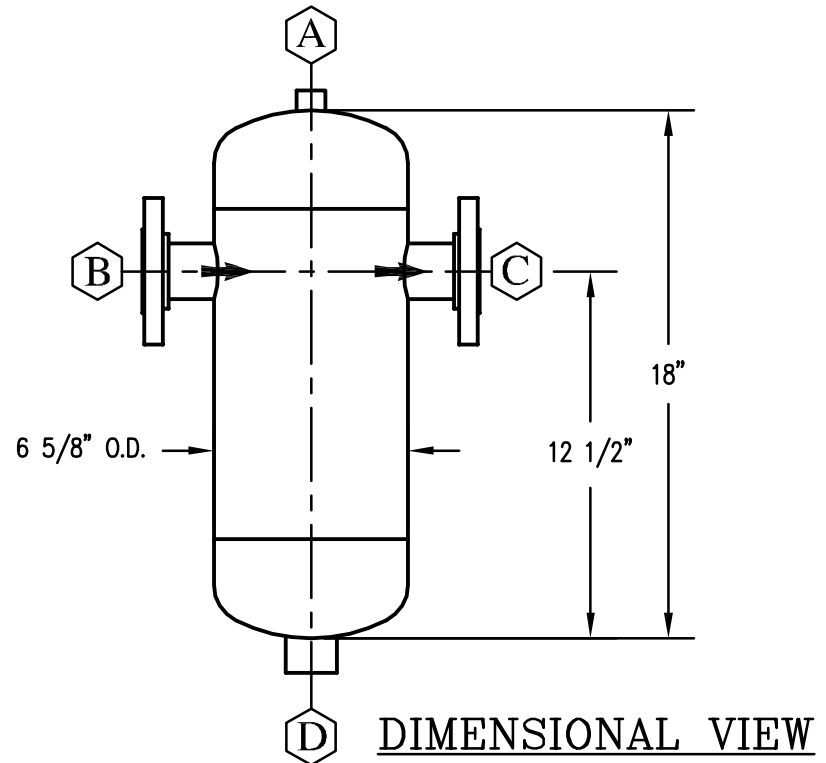

DIMENSIONAL VIEW

NOZZLE SCHEDULE				
MARK	SIZE	SPEC	NOZ. TYPE	FUNCTION
A	1/4"	6000#	CPLG	VENT
B	1 1/2"	150#	R.F.S.O.	INLET
C	1 1/2"	150#	R.F.S.O.	OUTLET
D	1"	3000#	CPLG	DRAIN

- NOTE: 1. DESIGNED, FABRICATED AND STAMPED IN ACCORDANCE WITH ASME CODE SECTION VIII, DIV. 1.
2. SEPARATORS AVAILABLE IN CARBON STEEL, 304 & 316 STAINLESS STEEL, OR OPTIONAL ALLOYS UPON REQUEST.
3. ALL DIMENSIONS ARE IN INCHES
4. WEIGHT (DRY) = 42 LBS.

<b>CONSTRUCTION</b>	
A.S.M.E. SECTION VIII DIVISION I	
A.S.M.E.  -U1 STAMP REQUIRED	
<b>DESIGN SPECIFICATIONS</b>	
DES. PRESS.	150 PSIG
DES. TEMP.	500° F.
FULL VACUUM	YES
CORR. ALL.	1/16"
HYDRO. TEST	195 PSIG
STRESS REL.	NONE REQ'D
RADIOGRAPH	NONE REQ'D
M.D.M.T	-20° F. @ 150 PSIG

REVISION: <u>0</u>			
NO.	DESCRIPTION	BY DATE	NO. DESCRIPTION
<b>DIDION SEPARATOR COMPANY</b>			
A DIVISION OF			
<b>DIDION'S MECHANICAL</b>		PH: (419) 483-2226	
<b>NOT BIGGEST....BEST!</b>		WEB: didionseparator.com	
DESCRIPTION: HORIZONTAL FLOW SEPARATOR		e-mail: dmech@didionsmech.com	
MODEL#: DST-1 1/2-150			
SALES DRAWING			
DRWN. JLD	DATE: 04/20/10	APPR.	DATE:
CHK.	DATE:	APPR.	DATE:
SCALE:	DRAWING NUMBER		REV.
D.M. NO.	DST-1.5-150-SALES		0
P.O. NO.			SHEET NO. 1 OF 1
THIS DRAWING AND ALL INFORMATION ON IT IS THE PROPERTY OF DIDION'S MECHANICAL. IT IS CONFIDENTIAL AND IS GIVEN TO YOU FOR A LIMITED PURPOSE AND MUST BE RETURNED ON REQUEST. NEITHER THIS DRAWING NOR ANY PART OF IT NOR ANY INFORMATION CONCERNING IT MAY BE COPIED, EXHIBITED OR FURNISHED TO OTHERS NOR MAY PHOTOGRAPHS BE TAKEN OF ANY ARTICLE FABRICATED OR ASSEMBLED FROM THIS DRAWING WITHOUT CONSENT OF DIDION'S MECHANICAL.			